

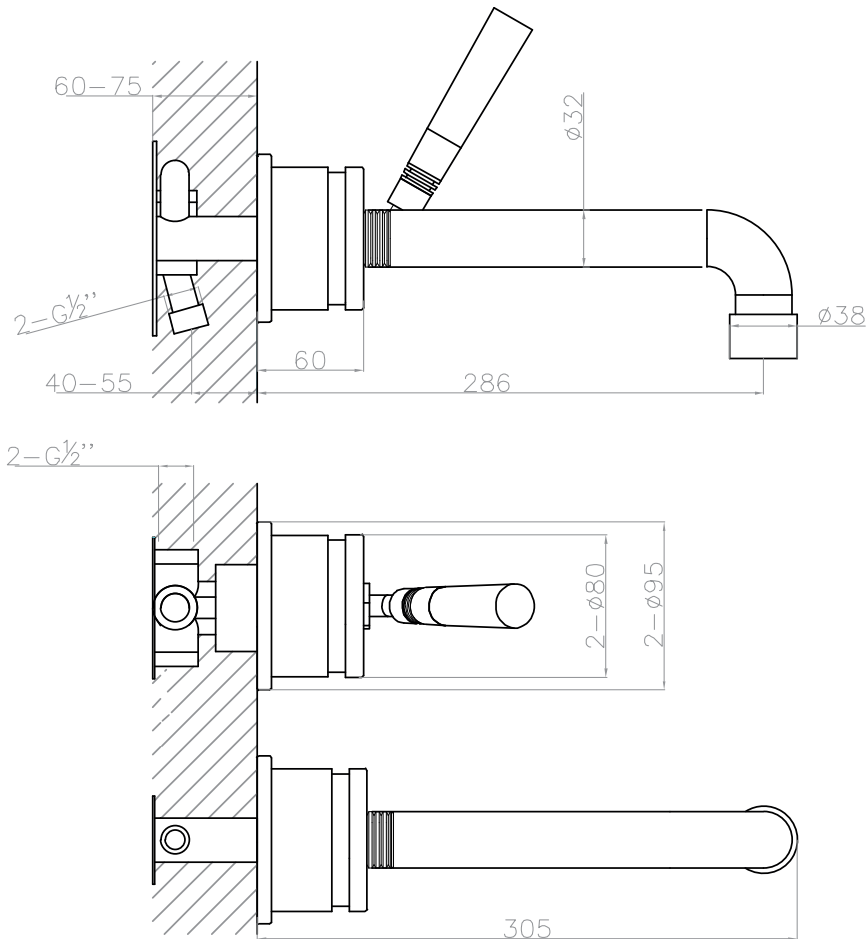

JEE-O soho wall basin mixer specifications

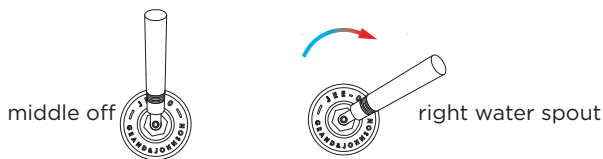

Note:
UV radiation and extreme temperature can affect the color and structure of the JEE-O soho basin wall surface.



Article code:	700-1500 ● Brushed stainless steel - RAW	Connection: Thread:	4 x G 1/2" (ø15mm / 0.6") British Standard Pipe (BSP)
	700-1502 ● Hammercoated black matt	Dimension package: Total weight: Package weight:	L 56 x W 34 x H 17 cm 4.4 kg 0.9 kg
Material: Coating:	Stainless Steel r304 1.5 Electro powder spray	2 year warranty	
Cartridge:	Sedal ceramic mixing mechanism (progressive), item code 005-0104		
Cleaning:	cleaning vinegar or alcohol		
Flow at water of 38°C /100,4°F:	10l p/m at 3bar pressure	HS code: Approvals:	84818011 SLS BS EN 817, SS 375, AS/NZS 4020, BS EN

